



conservation



# VIS RACLEUSE "amovible"

SCRAPING AUGER (REMOVABLE)

## TYPE VRA

Type VRA



## VIS RACLEUSE AVEC L'OPTION PIVOT SUPPORT

SCRAPING AUGER WITH PIVOT SUPPORT OPTION

- Pour silo ø 4,00 m à 15,11 m
- 2 versions : 15 ou 30 t/h.
- For silo diam. 4.00 to 15.11 m
- 2 versions: 15 or 30 t/h

Palier intermédiaire pour vis sur silos ø 11,55 m et supérieurs.

Intermediate bearing for silo augers diam. ≥11.55 m

valorisation

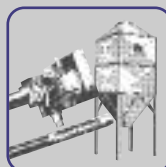
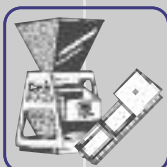
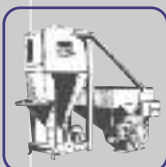
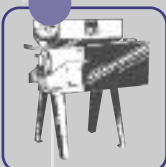

# CARACTÉRISTIQUES

CHARACTERISTICS

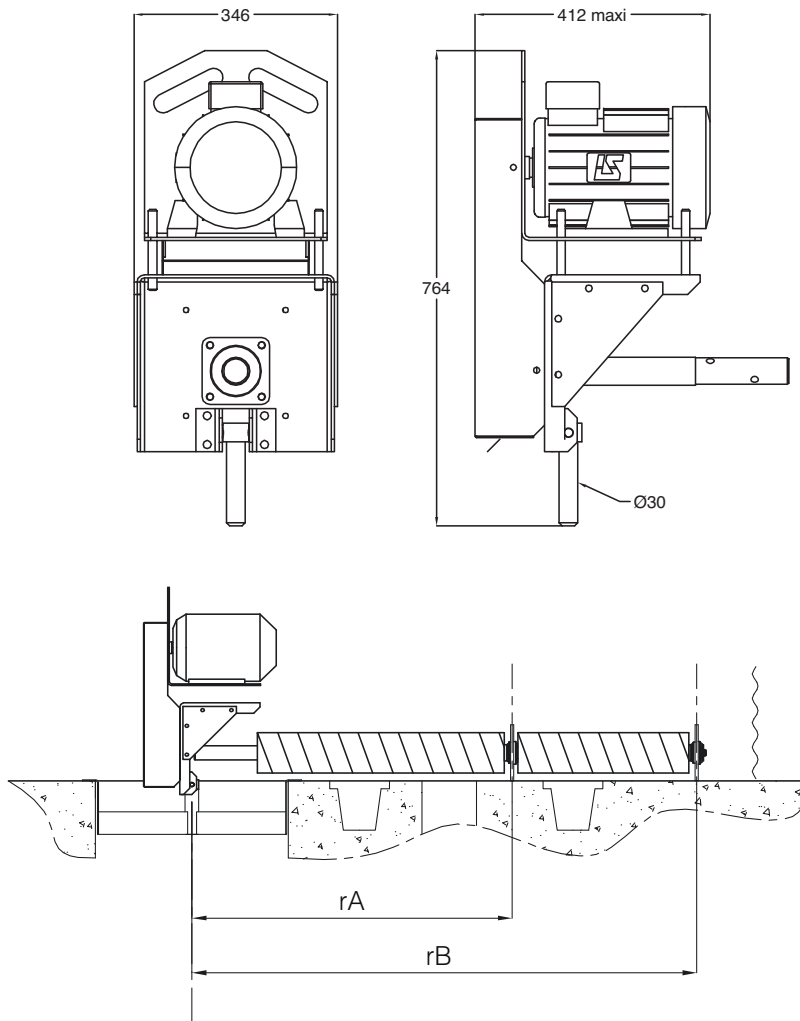

ø SILO	rA	rB
4,00 m		1,828 m
4,44 m		2,049 m
4,88 m		2,269 m
5,34 m		2,469 m
6,23 m		2,888 m
7,12 m		3,328 m
8,00 m		3,779 m
8,90 m		4,299 m
9,80 m		4,719 m
10,60 m		5,138 m
11,55 m	2,888 m	5,590 m
12,48 m	3,328 m	6,030 m
13,32 m	3,779 m	6,480 m
14,21 m	3,779 m	6,920 m
15,11 m	3,779 m	7,371 m

## ACCESSOIRES

ACCESSORIES

- Pivot support
- Auget central avec pivot support
- Auget latéral
- Pivot support
- Central auger with pivot support
- Lateral auger

**ATTENTION** au sens de la directive "machines" ce matériel est un sous ensemble et ne fait pas l'objet d'une déclaration de conformité.

Il est exclusivement réservé aux stockages non soumis à déclaration ou autorisation.

Le silo recevant cette vis doit impérativement être équipé de condamnation empêchant l'accès lors du fonctionnement.

Under the "machines" directive this equipment is a sub-assembly and is not subjected to a declaration of conformity.

It is exclusively to be used for storage purposes which are not subject to declaration or authorization.

The silo to receive this auger must be fitted with a locking system to prevent access during its operation.



ZI la Fréminière - 5, rue Jean Marie Texier  
BP 90210 - 35502 VITRE Cedex - FRANCE

Tél. : 33 (0)2 99 75 73 00  
Fax : 33 (0)2 99 75 73 20

e-mail : [fao.direction@fao.fr](mailto:fao.direction@fao.fr)

Site : [www.fao.fr](http://www.fao.fr)

Votre distributeur